



### FREE RIDE® FIFTH WHEEL HITCH

- 18,000 lb. rating (3,500 lb. vertical load)
- No towing hardware in your bed when you don't need it. Easy on/off design
- No drilling into your truck frame
- Side-to-side pivot of 10 degrees



### GOOD 2 GO™ GOOSENECK SYSTEM

#### Gooseneck Hitch

- Ball plate with 2-5/16" ball spins in/out
- 30,000 lb. rating (5,000 lb. vertical load)
- Requires only one 3" hole in truck bed

#### Gooseneck Adapter

Automatic latching coupler attaches to any 2-5/16" gooseneck ball.

- Converts fifth wheel trailer to gooseneck
- Drop down style coupler allows full range of motion for easy hookup and disconnect
- 30,000 lb. rating (7,500 lb. vertical load)
- 15" or 12" overall height



### RAIL RIDER™ COMPLETE SLIDER SYSTEM

- Also available as gooseneck slider
- Allows 9" extra cab clearance
- 18,000 lb. rating (3,500 lb. vertical load)

# FREE RIDE ADAPTER INSTALLATION

Congratulations on buying the Colibert FREE RIDE® Fifth Wheel Hitch for your gooseneck system. Rated to 18,000 lb. (3,500 lb. vertical load), our hitch is arguably the best in the market. It is light weight and is easy to remove leaving your truck bed free and clear.

The installation for the FREE RIDE® Fifth Wheel Hitch differs slightly from the attached owner's manual which uses Colibert's undercarriage installation kits. Please refer to this manual for the initial installation of the FREE RIDE® Fifth Wheel Hitch and the **revised parts list**.

#### New Parts Included:

- Adapted Base Unit
- "J" Bolt and Hardware

#### Parts Removed:

- Base Unit
- Wrench Assembly
- 2" x 3-1/2" Bolt
- 3/4" x 3-1/2" Bolt
- 1" Spacer
- Plastic Plugs

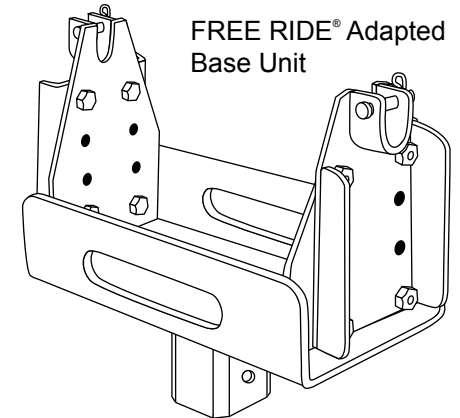

FREE RIDE® Adapted  
Base Unit



Detail of the "J" Bolt  
and Hardware  
installed into the FREE RIDE®  
Adapted Base Unit

Call toll-free or visit us online for the dealer nearest you.  
1-888-CE-HITCH [www.colibert.com](http://www.colibert.com)